

## FLAME GARD-TYPE II

SPECIAL ORDER AVAILABLE WITH LOCKING HANDLES

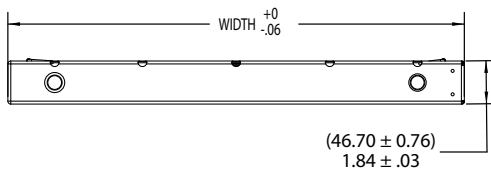
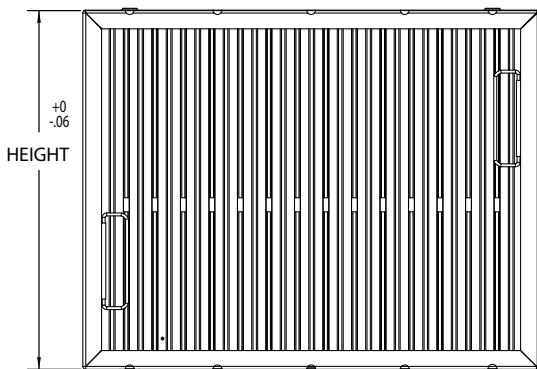

FLAME GARD-TYPE II

FILTER P/N	HEIGHT	WIDTH
201616 [406mm x 406mm]	15.50 [395mm]	15.50 [395mm]
201620 [406mm x 508mm]	15.50 [395mm]	19.50 [495mm]
201625 [406mm x 635mm]	15.50 [395mm]	24.50 [623mm]
202016 [508mm x 406mm]	19.50 [495mm]	15.50 [395mm]
202020 [508mm x 508mm]	19.50 [495mm]	19.50 [495mm]
202025 [508mm x 635mm]	19.50 [495mm]	24.50 [623mm]
202516 [635mm x 406mm]	24.50 [623mm]	15.50 [395mm]
202520 [635mm x 508mm]	24.50 [623mm]	19.50 [495mm]
201016 [254mm x 406mm]	9.50 [242mm]	15.50 [395mm]
201020 [254mm x 508mm]	9.50 [242mm]	19.50 [495mm]
201216 [305mm x 406mm]	11.50 [293mm]	15.50 [395mm]
201220 [305mm x 508mm]	11.50 [293mm]	19.50 [495mm]

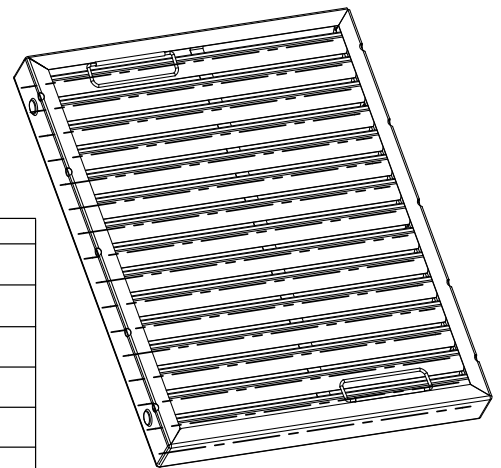



## FLAME GARD-TYPE II OPTIONAL LOCKING HANDLES

*Holes for handles & brackets installed with filter purchase. All filters are available with special Maryland Locking Handles. When ordering Maryland Locking Handles, add Suffix-MH to model number.*

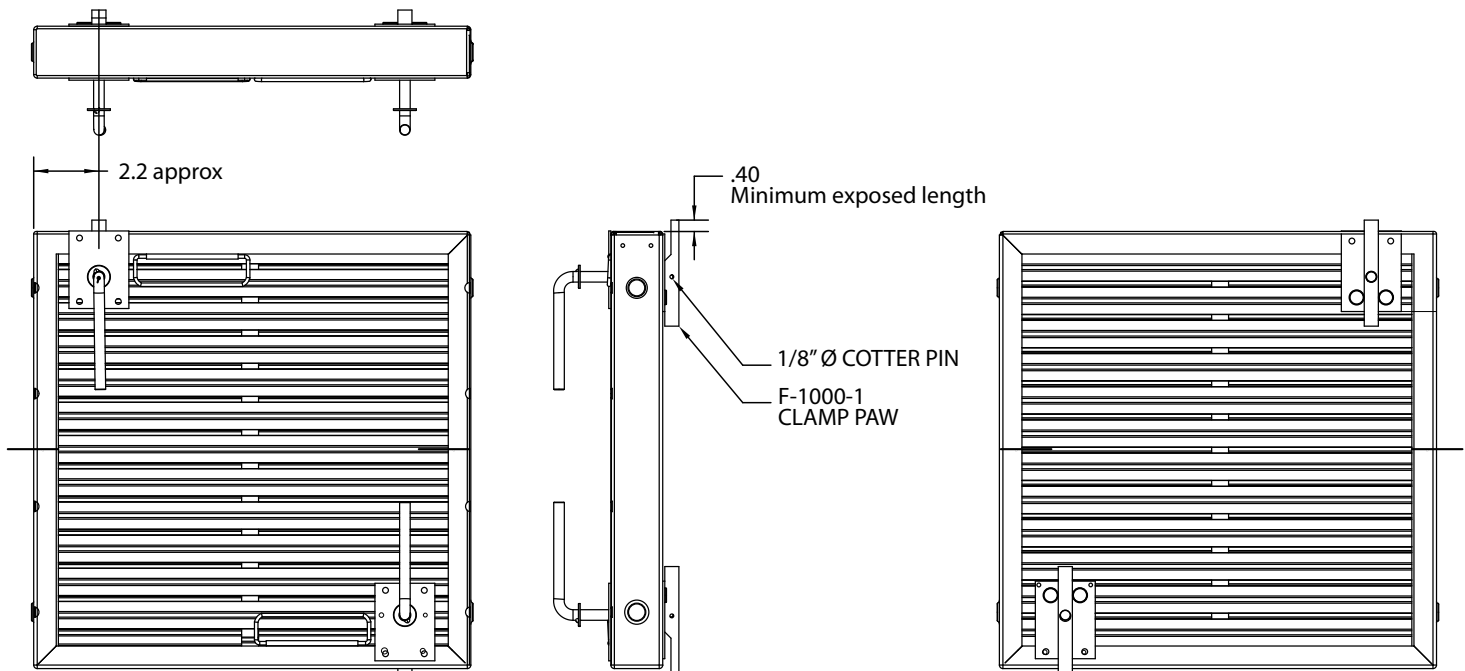

**FLAME GARD-TYPE II**  
*OPTIONAL HOOK TYPE MOUNTING BRACKETS*

*Holes for handles & brackets installed with filter purchase. When ordering Optional Hook Type Mounting Brackets, add Suffix-H to model number.*

